



# Intel<sup>®</sup> 945G Express Chipset Graphics and Memory Controller Hub (GMCH) for Embedded Applications

Thermal Design Guide

---

*August 2005*



INFORMATION IN THIS DOCUMENT IS PROVIDED IN CONNECTION WITH INTEL® PRODUCTS. EXCEPT AS PROVIDED IN INTEL'S TERMS AND CONDITIONS OF SALE FOR SUCH PRODUCTS, INTEL ASSUMES NO LIABILITY WHATSOEVER, AND INTEL DISCLAIMS ANY EXPRESS OR IMPLIED WARRANTY RELATING TO SALE AND/OR USE OF INTEL PRODUCTS, INCLUDING LIABILITY OR WARRANTIES RELATING TO FITNESS FOR A PARTICULAR PURPOSE, MERCHANTABILITY, OR INFRINGEMENT OF ANY PATENT, COPYRIGHT, OR OTHER INTELLECTUAL PROPERTY RIGHT.

Intel Corporation may have patents or pending patent applications, trademarks, copyrights, or other intellectual property rights that relate to the presented subject matter. The furnishing of documents and other materials and information does not provide any license, express or implied, by estoppel or otherwise, to any such patents, trademarks, copyrights, or other intellectual property rights.

Intel products are not intended for use in medical, life-saving, life-sustaining, critical control or safety systems, or in nuclear-facility applications. Intel may make changes to specifications and product descriptions at any time, without notice.

Intel may make changes to specifications and product descriptions at any time, without notice.

Designers must not rely on the absence or characteristics of any features or instructions marked "reserved" or "undefined." Intel reserves these for future definition and shall have no responsibility whatsoever for conflicts or incompatibilities arising from future changes to them.

The Intel® 945G Express Chipset Graphics and Memory Controller Hub (GMCH) for Embedded Applications may contain design defects or errors known as errata which may cause the product to deviate from published specifications. Current characterized errata are available on request.

MPEG is an international standard for video compression/decompression promoted by ISO. Implementations of MPEG CODECs, or MPEG enabled platforms may require licenses from various entities, including Intel Corporation.

This document and the software described in it are furnished under license and may only be used or copied in accordance with the terms of the license. The information in this document is furnished for informational use only, is subject to change without notice, and should not be construed as a commitment by Intel Corporation. Intel Corporation assumes no responsibility or liability for any errors or inaccuracies that may appear in this document or any software that may be provided in association with this document. Except as permitted by such license, no part of this document may be reproduced, stored in a retrieval system, or transmitted in any form or by any means without the express written consent of Intel Corporation.

Contact your local Intel sales office or your distributor to obtain the latest specifications and before placing your product order.

Copies of documents which have an order number and are referenced in this document, or other Intel literature, may be obtained by calling 1-800-548-4725, or by visiting Intel's website at <http://www.intel.com>.

AlertVIEW, AnyPoint, AppChoice, BoardWatch, BunnyPeople, CablePort, Celeron, Chips, CT Connect, CT Media, Dialogic, DM3, EtherExpress, ETOX, FlashFile, i386, i486, i960, iCOMP, InstantIP, Intel, Intel logo, Intel386, Intel486, Intel740, IntelDX2, IntelDX4, IntelSX2, Intel Create & Share, Intel GigaBlade, Intel InBusiness, Intel Inside, Intel Inside logo, Intel NetBurst, Intel NetMerge, Intel NetStructure, Intel Play, Intel Play logo, Intel SingleDriver, Intel SpeedStep, Intel StrataFlash, Intel TeamStation, Intel Xeon, Intel XScale, IPLink, Itanium, LANDesk, LanRover, MCS, MMX, MMX logo, Optimizer logo, OverDrive, Paragon, PC Dads, PC Parents, PDCharm, Pentium, Pentium II Xeon, Pentium III Xeon, Performance at Your Command, RemoteExpress, Shiva, SmartDie, Solutions960, Sound Mark, StorageExpress, The Computer Inside., The Journey Inside, TokenExpress, Trillium, VoiceBrick, Vtune, and Xircom are trademarks or registered trademarks of Intel Corporation or its subsidiaries in the United States and other countries.

\*Other names and brands may be claimed as the property of others.

Copyright © Intel Corporation 2005. All rights reserved.

# Contents

<b>1</b>	<b>Introduction.....</b>	<b>5</b>
1.1	Scope.....	5
1.2	Terminology.....	5
1.3	Reference Documents.....	7
<b>2</b>	<b>Product Specifications.....</b>	<b>8</b>
2.1	Package Description.....	8
2.2	Non-Grid Array Package Ball Placement.....	8
2.3	Package Loading Specifications.....	9
2.4	Thermal Specifications.....	9
2.5	Thermal Design Power (TDP).....	9
2.5.1	Methodology.....	10
2.5.2	Application Power.....	10
2.5.3	Specifications.....	10
<b>3</b>	<b>Thermal Metrology.....</b>	<b>11</b>
3.1	Case Temperature Measurements.....	11
3.1.1	Thermocouple Attach Methodology.....	11
3.2	Airflow Characterization.....	12
<b>4</b>	<b>Reference Thermal Solution.....</b>	<b>14</b>
4.1	Operating Environment.....	14
4.1.1	1U Form Factor Operating Environment.....	14
4.2	Mechanical Design Envelope.....	16
4.3	Thermal Solution Assembly.....	16
4.3.1	Solder-Down Anchors.....	16
4.3.2	Thermal Interface Material (TIM).....	17
4.4	Board-Level Component Keep-outs.....	17
4.5	Environmental Reliability Requirements.....	18
<b>Appendix A</b>	<b>Enabled Suppliers.....</b>	<b>19</b>
<b>Appendix B</b>	<b>Mechanical Drawings.....</b>	<b>20</b>

## Figures

Figure 1	Intel® 945G Express Chipset GMCH Non-Grid Array.....	8
Figure 2	0° Angle Attach Methodology (Top View).....	11
Figure 3	0° Angle Attach Heat Sink Modifications (Generic Heat Sink Side and Bottom View).....	12
Figure 4	Airflow Temperature Measurement Locations.....	12
Figure 5	Thermal Solution Performance.....	15
Figure 6	Typical 1U Server Motherboard Component Placement.....	15



Figure 7 1U GMCH Heat Sink ..... 16  
 Figure 8 GMCH Torsional Clip Heat Sink Motherboard Component Keep-out..... 17  
 Figure 9 GMCH Retention Mechanism Component Keep-out Zone ..... 18  
 Figure 10 Package Drawing ..... 21  
 Figure 11 Reference Thermal Solution Assembly ..... 22  
 Figure 12 1U Copper Heat Sink..... 23  
 Figure 13 Heat Sink Gasket..... 24  
 Figure 14 Torsional Heat Sink Attach Clip..... 25

## Tables

Table 1 Chipset Loading Specifications ..... 9  
 Table 2 GMCH Case Temperature Specifications ..... 9  
 Table 3 GMCH Thermal Design Power Specifications..... 10  
 Table 4 GMCH Thermal Requirements ..... 14  
 Table 5 Reference Thermal Solution Environmental Reliability Requirements ..... 18  
 Table 6 1U Intel Reference Heat Sink Enabled Suppliers ..... 19

## Revision History

Date	Revision	Description
August 2005	001	Initial release.

# 1 Introduction

As the complexity of computer systems increases, so do power dissipation requirements. The additional power of next generation systems must be properly dissipated. Heat can be dissipated using improved system cooling, selective use of ducting, and/or passive heat sinks.

The objective of thermal management is to ensure that the temperatures of all components in a system are maintained within functional limits. The functional temperature limit is the range within which the electrical circuits can be expected to meet specified performance requirements. Operation outside the functional limit can degrade system performance, cause logic errors, or cause component and/or system damage. Temperatures exceeding the maximum operating limits may result in irreversible changes in the operating characteristics of the component. The goal of this document is to provide an understanding of the operating limits of the Intel® 945G Graphics and Memory Controller Hub (GMCH) Chipset and discuss a reference thermal solution.

The simplest and most cost-effective method to improve the inherent system cooling characteristics of the GMCH is through careful design and placement of fans, vents, and ducts. When additional cooling is required, component thermal solutions may be implemented in conjunction with system thermal solutions. The size of the fan or heat sink can be varied to balance size and space constraints with acoustic noise.

This document presents the conditions and requirements to properly design a cooling solution for systems that implement the 945G Express Chipset GMCH. Properly designed solutions provide adequate cooling to maintain the 945G Express Chipset GMCH case temperature at or below thermal specifications. This is accomplished by providing a low local-ambient temperature, ensuring adequate local airflow, and minimizing the case to local-ambient thermal resistance. By maintaining the 945G Express Chipset GMCH case temperature at or below those recommended in this document, a system designer can ensure the proper functionality, performance, and reliability of this chipset.

## 1.1 Scope

This document applies only to the implementation of the 945G Express Chipset GMCH in the 1U and larger server form factors. For more information on server system form factors visit, [www.ssiforum.org](http://www.ssiforum.org). For information on the desktop computer application of the 945G Express Chipset GMCH, refer to the *Intel® 945G/945P Express Chipset Family Thermal and Mechanical Design Guidelines*.

## 1.2 Terminology

Term	Description
BGA	Ball grid array. A package type defined by a resin-fiber substrate where a die is mounted and bonded. The primary electrical interface is an array of solder balls attached to the substrate opposite the die and molding compound.
FC-BGA	Flip chip ball grid array. A package type defined by a plastic substrate where a die is mounted using an underfill C4 (Controlled Collapse Chip Connection) attach style. The primary electrical interface is an array of solder balls attached to the substrate opposite the die. Note that the device arrives at the customer with solder balls attached.
Intel® ICH7	Intel® I/O Controller Hub 7. The chipset component that contains the primary PCI interface, LPC interface, USB, ATA, and/or other legacy functions.

Term	Description
mBGA	Mini ball grid array. A smaller version of the BGA. Wire bonded package with die encased with a mold encapsulant.
GMCH	Graphic memory controller hub. The chipset component that contains the processor and memory interface and integrated graphics core.
$T_A$	The measured ambient temperature locally to the component of interest. The ambient temperature should be measured just upstream of airflow for a passive heat sink or at the fan inlet for an active heat sink. Also referred to as $T_{LA}$ .
$T_C$	The measured case temperature of a component. For processors, it is measured at the geometric center of the integrated heat spreader (IHS). For other component types, it is generally measured at the geometric center of the top of the die or case.
$T_S$	The measured temperature of the heat sink. $T_S$ is measured at a point on the bottom of the heat sink base that corresponds to the location of the $T_C$ measurement.
$T_{C-MAX}$	The maximum case/die temperature with an attached heat sink. This temperature is measured at the geometric center of the top of the package case/die.
$T_{C-MIN}$	The minimum case/die temperature with an attached heat sink. This temperature is measured at the geometric center of the top of the package case/die.
TDP	Thermal design power is specified as the highest sustainable power level of most or all of the real applications expected to be run on the given product, based on extrapolations in both hardware and software technology over the life of the component. Thermal solutions should be designed to dissipate this target power level.
TIM	Thermal interface material: thermally conductive material installed between two surfaces to improve heat transfer and reduce interface contact resistance.
lfm	Linear feet per minute. Unit of airflow speed.
CFM	Cubic feet per minute. Volumetric fluid flow rate.
$\Psi_{CA}$	Case-to-ambient thermal characterization parameter (Psi). A measure of thermal solution performance using total package power. Defined as $(T_C - T_A) / \text{Total Package Power}$ . Heat source size should always be specified for $\Psi$ measurements.
$\Psi_{SA}$	Sink-to-ambient thermal characterization parameter (Psi). A measure of the heat sink performance using total package power. Defined as $(T_S - T_A) / \text{Total Package Power}$ . Heat source size should always be specified for $\Psi$ measurements.
$\Psi_{CS}$	Case-to-sink thermal characterization parameter (Psi). A measure of the thermal interface material's performance using total package power. Defined as $(T_C - T_S) / \text{Total Package Power}$ . Heat source size should always be specified for $\Psi$ measurements.

## 1.3 Reference Documents

Document	Comments
<i>Intel® 945G/945P Express Chipset Family Datasheet</i>	Available electronically (see Note)
<i>Intel® 945G/945P Express Chipset Family Thermal and Mechanical Design Guidelines</i>	Available electronically (see Note)
<i>Intel® I/O Controller Hub 7 (ICH7) Datasheet</i>	Available electronically (see Note)
<i>Intel® I/O Controller Hub 7 (ICH7) Family Thermal Design Guidelines</i>	Available electronically (see Note)
<i>Intel® Pentium® 4 Processors 570/571, 560/561, 550/551, 540/541, 530/531, and 520/521 Supporting Hyper-Threading Technology Datasheet</i>	Available electronically (see Note)
<i>Intel® Pentium® 4 Processor on 90 nm Process in the 775-Land LGA Package Thermal and Mechanical Design Guidelines</i>	Available electronically (see Note)
<i>Intel® Pentium 4 Processor on 90 nm Process in the 775-Land LGA Package Thermal Design Guide for Embedded Applications</i>	Available electronically (see Note)
<i>LGA775 Socket Mechanical Design Guide</i>	Available electronically (see Note)
<i>Thin Client Electronic Bay Server Specifications</i>	<a href="http://www.ssiforum.org">http://www.ssiforum.org</a>
Various System Thermal Design Suggestions	<a href="http://www.formfactors.org">http://www.formfactors.org</a>

**NOTE:** Contact your Intel field sales representative for the latest revision and order number of this document.

## 2 Product Specifications

### 2.1 Package Description

The Intel® 945G Express Chipset GMCH is available in a 34 mm (1.34 in.) x 34 mm (1.34 in.) Flip Chip Ball Grid Array (FCBGA) package with 1202 solder balls. The die size is currently 9.6 mm (0.378 in.) x 10.6 mm (0.417 in.). A mechanical drawing of the package is shown in Figure 10, Appendix B.

### 2.2 Non-Grid Array Package Ball Placement

The 945G Express Chipset GMCH package utilizes a “balls anywhere” non-standard grid ball pattern. Minimum ball pitch is 0.8 mm (0.031 in.), but ball ordering does not follow a 0.8 mm grid. Board designers should ensure correct ball placement when designing for the non-grid array pattern. For exact ball locations relative to the package, contact your Intel field sales representative.

Figure 1 Intel® 945G Express Chipset GMCH Non-Grid Array

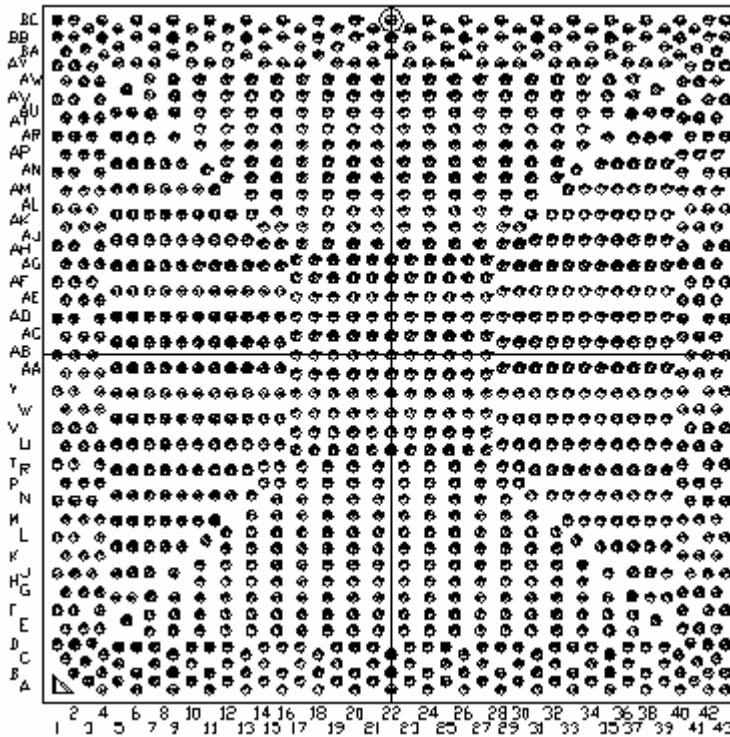

## 2.3 Package Loading Specifications

Table 1 provides static load specifications for the chipset package. This mechanical maximum load limit should not be exceeded during heat sink assembly, shipping conditions, or standard use condition. Also, any mechanical system or component testing should not exceed the maximum limit. The chipset package substrate should not be used as a mechanical reference or load-bearing surface for the thermal and mechanical solution. The minimum loading specification must be maintained by any thermal and mechanical solution.

**Table 1 Chipset Loading Specifications**

Parameter	Maximum	Notes
Static	15 lbf	1, 2, 3

**NOTES:**

1. These specifications apply to uniform compressive loading in a direction normal to the chipset package
2. This is the maximum force that can be applied by a heat sink retention clip. The clip must also provide the minimum specified load on the chipset package.
3. These specifications are based on limited testing for design characterization. Loading limits are for the package only.

## 2.4 Thermal Specifications

To ensure proper operation and reliability of the 945G Express Chipset GMCH, the temperature must be at or below the maximum value specified in Table 2. System and component level thermal enhancements are required to dissipate the heat generated and maintain the GMCH within specifications. Section 3 provides the thermal metrology guidelines for case temperature measurements.

The GMCH should also operate above the minimum case temperature specification listed in the table below.

**Table 2 GMCH Case Temperature Specifications**

Parameter	Value
$T_{C-MAX}$	C
$T_{C-MIN}$	$\geq 0^{\circ}C$

**NOTE:** Thermal specifications assume an attached heat sink is present.

## 2.5 Thermal Design Power (TDP)

Thermal design power (TDP) is the estimated power dissipation of the GMCH based on normal operating conditions including  $V_{CC}$  and  $T_{C-MAX}$  while executing real worst-case power intensive applications. This value is based on expected worst-case data traffic patterns and usage of the chipset and does not represent a specific software application. TDP attempts to account for expected increases in power due to variation in chipset current consumption due to silicon process variation, processor speed, DRAM capacitive bus loading and temperature. However, since these variations are subject to change, the TDP cannot guarantee that all applications will not exceed the TDP value.

The system designer must design a thermal solution for the GMCH such that it maintains  $T_C$  below  $T_{C-MAX}$  for a sustained power level equal to TDP. Please note that the  $T_{C-MAX}$  specification

is a requirement for a sustained power level equal to TDP, and that the case temperature must be maintained at temperatures less than  $T_{C-MAX}$  when operating at power levels less than TDP. This temperature compliance is to ensure chipset reliability over its useful life. The TDP value can be used for thermal design if the chipset thermal protection mechanisms are enabled. Intel chipsets incorporate a hardware-based fail-safe mechanism to keep the product temperature in spec in the event of unusually strenuous usage above the TDP power.

## 2.5.1 Methodology

### 2.5.1.1 Pre-Silicon

In order to determine TDP for pre-silicon products in development, it is necessary to make estimates based on analytical models. These models rely on extensive knowledge of the past chipset power dissipation behavior along with knowledge of planned architectural and process changes that may affect TDP. Knowledge of applications available today and their ability to stress various components of the chipset is also included in the model. Since the number of applications available today is beyond what Intel can test, only real world high-power applications are tested to predict TDP. The values determined are used to set specific data transfer rates. The projection for TDP assumes GMCH operation at  $T_{C-MAX}$ . The TDP estimate also includes a margin to account for process variation.

### 2.5.1.2 Post-Silicon

Once the product silicon is available, post-silicon validation is performed to assess the validity of pre-silicon projections. Testing is performed on both commercially available and synthetic high power applications and power data is compared to pre-silicon estimates. Post-silicon validation may result in a small adjustment to pre-silicon TDP estimates.

## 2.5.2 Application Power

Designing to the TDP can ensure a particular thermal solution can meet the cooling needs of future applications. Testing with currently available commercial applications has shown they may dissipate power levels below the published TDP specification in Section 2.5.3. Intel strongly recommends that thermal engineers design to the published TDP specification to develop a robust thermal solution that will meet the needs of current and future applications.

## 2.5.3 Specifications

The GMCH is estimated to dissipate the Thermal Design Power values provided in Table 3 when using two (2) DIMMs of 667 MHz dual channel DDR2 with a 1066 MHz processor system bus speed. The graphics core is assumed to run at 400 MHz. Without thermal solutions, FCBGA packages have poor heat transfer capability into the board and have minimal thermal capability. Intel requires that system designers plan for an attached heat sink when using the GMCH.

**Table 3 GMCH Thermal Design Power Specifications**

Component	System Bus Speed	Memory Frequency	TDP Value
Intel® 82945G Express Chipset GMCH	1066 MHz	667 MHz	22.2 W

## 3 Thermal Metrology

The system designer must measure temperatures in order to accurately determine the thermal performance of the system. Intel has established guidelines for proper techniques of measuring chipset component case temperatures.

### 3.1 Case Temperature Measurements

To ensure functionality and reliability, the chipset GMCH is specified for proper operation when  $T_C$  is maintained at or below the maximum temperature listed in Table 2. The surface temperature at the geometric center of the die corresponds to  $T_C$ . Measuring  $T_C$  requires special care to ensure an accurate temperature reading.

Temperature differences between the temperature of a surface and the surrounding local ambient air can introduce error in the measurements. The measurement errors could be due to a poor thermal contact between the thermocouple junction and the surface of the package, heat loss by radiation and/or convection, conduction through thermocouple leads, or contact between the thermocouple cement and the heat sink base. To minimize these measurement errors a thermocouple attach with a zero-degree methodology is recommended.

#### 3.1.1 Thermocouple Attach Methodology

1. Mill a 3.3 mm (0.13 in.) diameter hole centered on bottom of the heat sink base. The milled hole should be approximately 1.5 mm (0.06 in.) deep.
2. Mill a 1.3 mm (0.05 in.) wide slot, 0.5 mm (0.02 in.) deep, from the centered hole to one edge of the heat sink. The slot should be parallel to the heat sink fins (see Figure 3).
3. Attach thermal interface material (TIM) to the bottom of the heat sink base.
4. Cut out portions of the TIM to make room for the thermocouple wire and bead. The cutouts should match the slot and hole milled into the heat sink base.
5. Attach a 36-gauge or smaller calibrated K-type thermocouple bead or junction to the center of the top surface of the die using a high thermal conductivity cement. During this step, make sure no contact is present between the thermocouple cement and the heat sink base because any contact will affect the thermocouple reading.

**Caution:** It is critical that the thermocouple bead makes contact with the die (see Figure 2).

6. Attach heat sink assembly to the GMCH, and route thermocouple wires out through the milled slot.

**Figure 2 0° Angle Attach Methodology (Top View)**

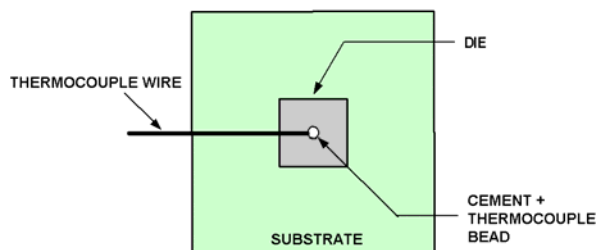

**NOTE:** Drawing not to scale.

**Figure 3 0° Angle Attach Heat Sink Modifications (Generic Heat Sink Side and Bottom View)**

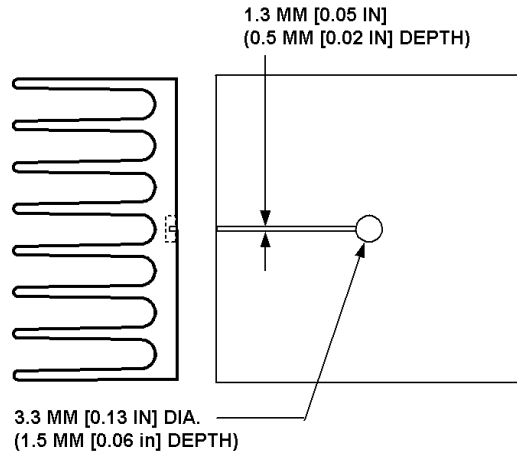

NOTE: Drawing not to scale.

### 3.2 Airflow Characterization

Figure 4 describes the recommended location for air temperature measurements measured relative to the component. For a more accurate measurement of the average approach air temperature, Intel recommends averaging temperatures recorded from two thermocouples spaced about 25 mm (1.0 in.) apart. Locations for both single and paired thermocouples are presented.

**Figure 4 Airflow Temperature Measurement Locations**

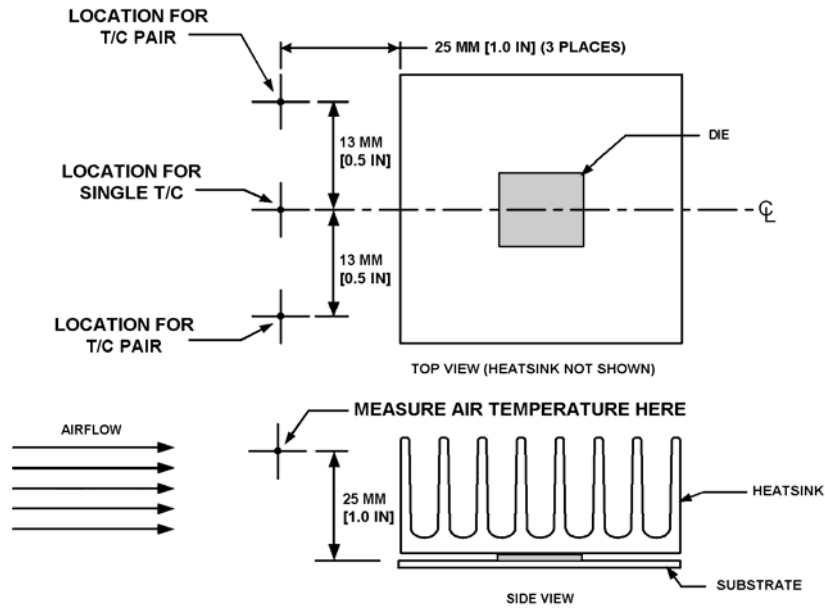

Airflow velocity should be measured using industry standard air velocity sensors. Typical airflow sensor technology may include hot wire anemometers. Figure 4 provides guidance for airflow velocity measurement locations. These locations are for a typical JEDEC test setup and may not



be compatible with chassis layouts due to the proximity of the processor to the GMCH. The user may have to adjust the locations for a specific chassis. Be aware that sensors may need to be aligned perpendicular to the airflow velocity vector or an inaccurate measurement may result. Measurements should be taken with the chassis fully sealed in its operational configuration to achieve a representative airflow profile within the chassis.

## 4 Reference Thermal Solution

The reference component thermal solution for the Intel® 945G Express Chipset GMCH for 1U and larger server platforms utilizes a wire clip and motherboard anchors. This chapter provides detailed information on operating environment assumptions, heat sink manufacturing, and mechanical reliability requirements for the GMCH. For information on the Intel® ATX and BTX reference design for the GMCH heat sink refer to the *Intel® 945G/945P Express Chipset Family Thermal and Mechanical Design Guidelines*.

### 4.1 Operating Environment

The operating environment of the GMCH will differ depending on system configuration and motherboard layout. This section will define operating environment boundary conditions that are typical for 1U server form factor. The system designer should perform analysis on platform operating environment to assess impact to thermal solution selection.

#### 4.1.1 1U Form Factor Operating Environment

The reference thermal solution compatible with the 1U form factor was designed assuming a maximum local ambient air temperature,  $T_{LA}$ , of 55° C with a minimum airflow velocity of 200 lfm (1.02 m/s) present 25 mm (1 in.) directly in front of the heat sink air inlet side. The system integrator should note that board layout may be such that there will not be 25mm (1 in.) between the processor heat sink and the GMCH. The potential for increased airflow speeds may be realized by ensuring that airflow from the processor thermal solution exhausts in the direction of the GMCH heat sink. In addition, GMCH board placement should ensure that the GMCH heat sink is within the air exhaust area of the processor heat sink. An example of typical 1U server layout is shown in Figure 6. This layout is based on the Thin Electronics Bay specification located at <http://www.ssiforum.org>.

Assuming these boundary conditions are met, the reference thermal solutions will meet the thermal specifications for the 945G GMCH. Table 4 shows the required thermal performance for the GMCH. The thermal designer must carefully select the location to measure airflow to get a representative sampling. These environmental assumptions are based on a system at sea level.

**Table 4 GMCH Thermal Requirements**

TDP (W)	Required $\Psi_{CA}$ at $T_{LA} = 55^{\circ} \text{C}$
22.2	1.98° C/W

**NOTE:**  $T_{LA}$  is defined as the local (internal) ambient temperature measured directly upstream from the heat sink airflow inlet.

The thermal performance of the reference thermal solution for the Intel® 945G Express Chipset GMCH for the 1U server form factor is show in Figure 5. This figure shows the performance of the reference thermal solution at sea level based on lab test data. This testing does not imply any statistical significance and was performed to verify that the thermal solution is performing within expectations. It is the responsibility of the system integrator to perform validation on the entire thermal solution including heat sink, thermal interface material, and attach mechanism.

Figure 5 Thermal Solution Performance

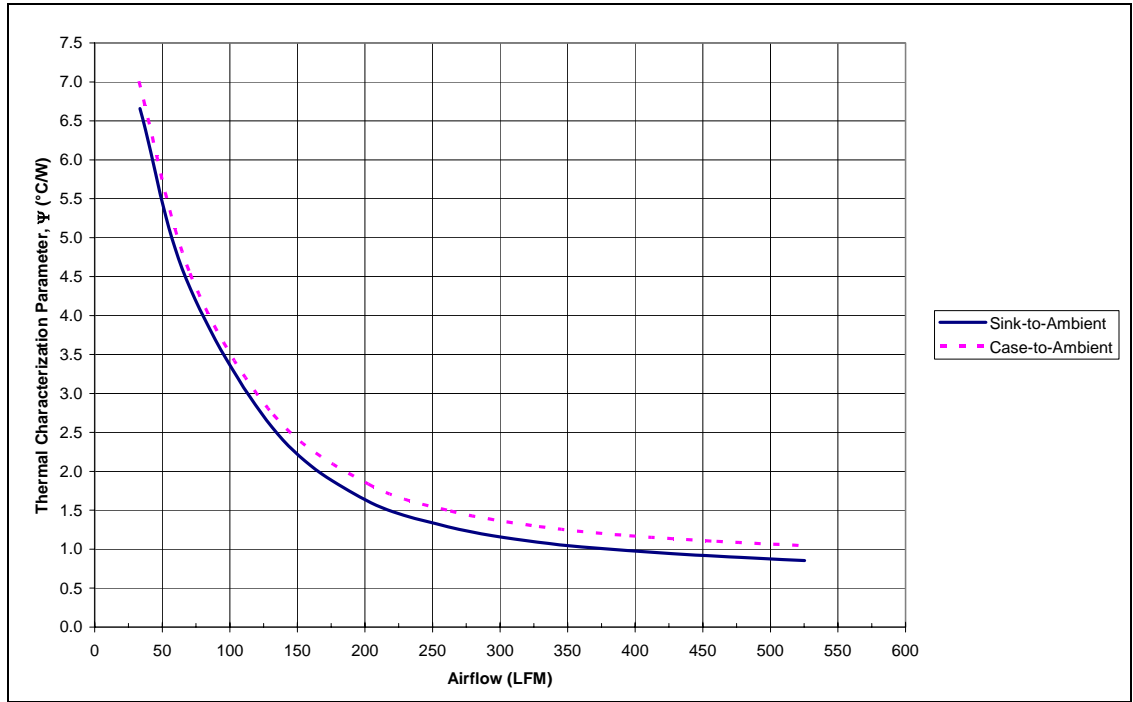
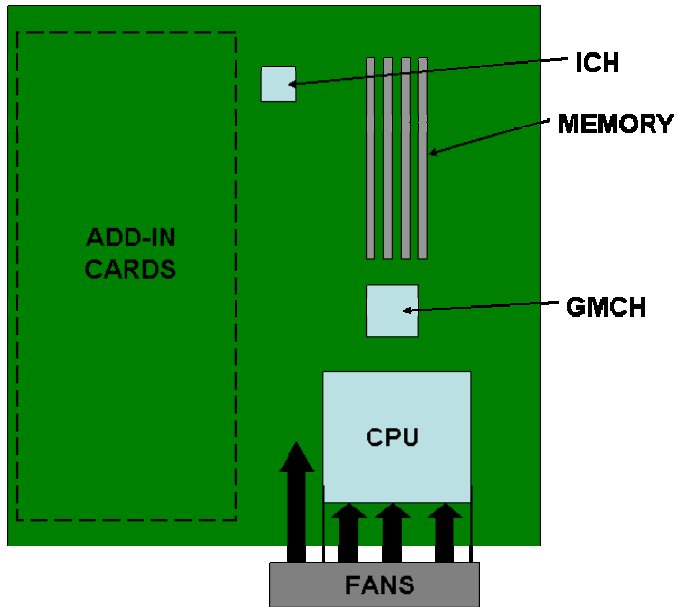

Figure 6 Typical 1U Server Motherboard Component Placement



**Caution:** Heat sink orientation alone does not guarantee that 200 lfm (1.02 m/s) airflow speed will be achieved. The system integrator should use analytical or experimental means to determine whether a system design provides adequate airflow speed for a particular GMCH heat sink.

## 4.2 Mechanical Design Envelope

The motherboard component keep-out restrictions for the GMCH on a 1U platform are included in Section 4.4, Figure 8 and Figure 9.

This heat sink extends 32.32 mm (1.272 in.) nominally above the board when mounted. System integrators should ensure no board or chassis components would intrude into the volume occupied by the GMCH thermal solution.

## 4.3 Thermal Solution Assembly

The reference thermal solution for the GMCH for the 1U server platform is shown in Figure 7 and Appendix B and is a copper heat sink attached to the motherboard with a wire clip and two motherboard anchors. The heat sink is attached to the motherboard by assembling the anchors into the board, placing the heat sink over the GMCH and then fastening the clip to the anchors. A thermal interface material (Honeywell\* PCM45F) is pre-applied to the heat sink bottom over an area which contacts the package die.

For information on the reference solution for the ATX and BTX form factors refer to the *Intel® 945G/945P Express Chipset Family Thermal and Mechanical Design Guidelines*.

**Figure 7** 1U GMCH Heat Sink

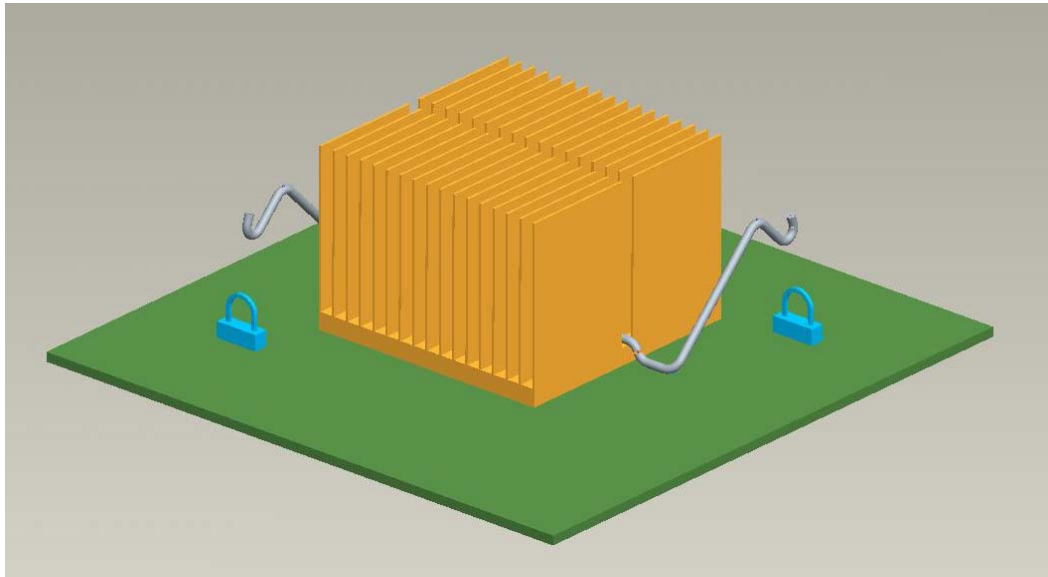

### 4.3.1 Solder-Down Anchors

For platforms that have very limited board space, a clip retention solder-down anchor has been developed to minimize the impact of clip retention on the board. It is based on a standard three-pin jumper and is soldered to the board like any common through-hole header. A new anchor design is available with 45° bent leads to increase the anchor attach reliability over time. The part number and vendor information are contained in Appendix A.

### 4.3.2 Thermal Interface Material (TIM)

A thermal interface material provides improved conductivity between the die and heat sink. It is important to understand and consider the impact of the interface between the die and heat sink base on the overall thermal solution. Specifically, the bond line thickness, interface material area, and interface material thermal conductivity must be selected to optimize the thermal solution.

It is important to minimize the thickness of the TIM, commonly referred to as the bond line thickness. A large gap between the heat sink base and the die yields a greater thermal resistance. The thickness of the gap is determined by the flatness of both the heat sink base and the die, plus the thickness of the TIM, and the clamping force applied by the heat sink attachment method. To ensure proper and consistent thermal performance, the TIM and application process must be properly designed.

The 945G GMCH reference thermal solution uses Honeywell\* PCM45F. Alternative materials can be used at the user's discretion. Regardless, the entire heat sink assembly, including the heat sink, TIM, attach method must be validated for specific applications.

## 4.4 Board-Level Component Keep-outs

The locations of the hole patterns and motherboard component keep-outs for the GMCH can be seen in Figure 8 and Figure 9. Dimensions are in inches.

**Figure 8 GMCH Torsional Clip Heat Sink Motherboard Component Keep-out**

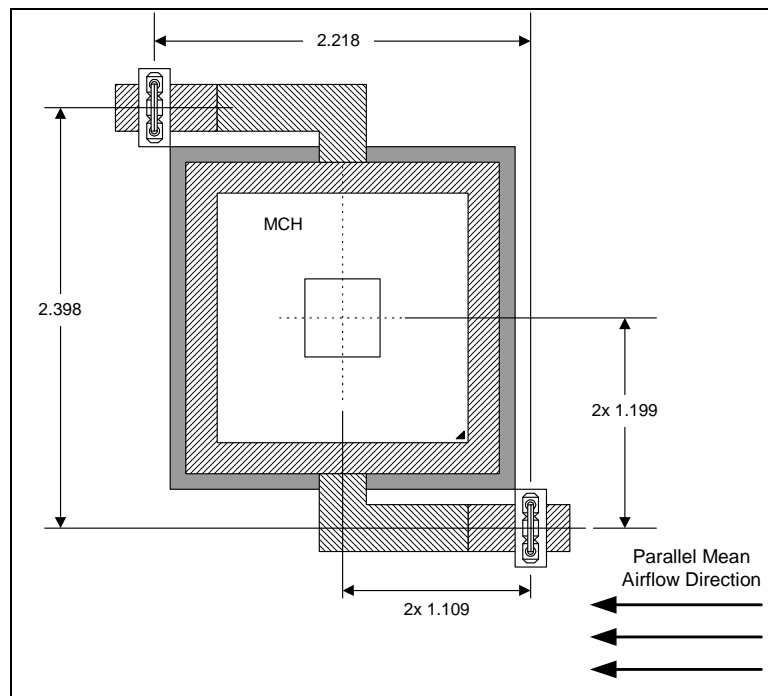

**Figure 9 GMCH Retention Mechanism Component Keep-out Zone**

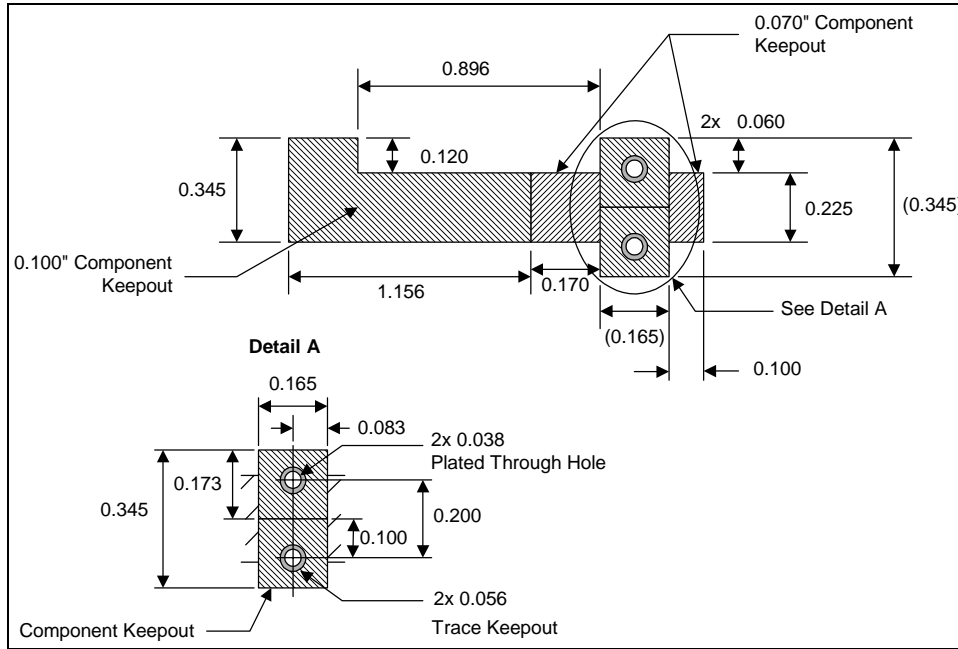

## 4.5 Environmental Reliability Requirements

The environmental reliability requirements for the reference thermal solution are shown in Table 5. These should be considered as general guidelines. Validation test plans should be defined by the user based on anticipated use conditions and resulting reliability requirements.

**Table 5 Reference Thermal Solution Environmental Reliability Requirements**

Test <sup>1</sup>	Requirement	Pass/Fail Criteria <sup>2</sup>
Mechanical Shock	<ul style="list-style-type: none"> <li>3 drops for + and - directions in each of 3 perpendicular axes (i.e., total 18 drops).</li> <li>Profile: 50 G trapezoidal waveform, 11 ms duration, 4.3 m/s (170 in/s) minimum velocity change.</li> <li>Setup: Mount sample board on test fixture. Include 550 g processor heat sink.</li> </ul>	Visual/electrical check Cross section should have crack length <50%
Random Vibration	<ul style="list-style-type: none"> <li>Duration: 10 min/axis, 3 axes</li> <li>Frequency Range: 5 Hz to 500 Hz</li> <li>Power Spectral Density (PSD) Profile: 3.13 g RMS</li> </ul>	Visual/electrical check Cross section should have crack length <50%
Thermal Cycling	<ul style="list-style-type: none"> <li>-40° C to +85° C, 900 cycles</li> </ul>	Thermal performance
Unbiased Humidity	<ul style="list-style-type: none"> <li>85% relative humidity / 55° C, 1000 hours</li> </ul>	Visual check

**NOTE:**

- The above tests should be performed on a sample size of at least 12 assemblies from 3 different lots of material.
- Additional pass/fail criteria may be added at the discretion of the user.

## Appendix A Enabled Suppliers

The following table lists enabled suppliers for the Intel® 945G Express Chipset GMCH reference thermal solution.

**Table 6 1U Intel Reference Heat Sink Enabled Suppliers**

Component	Supplier	Intel Part Number	Vendor Part Number	Contact Information
1U copper heat sink, gasket, and pre-applied Honeywell* PCM45F TIM	Cooler Master*	N/A	ECB-00265-01-GP	Wendy Lin (USA) (510)770-8566 ext. 211 wendy@coolermaster.com
Thermal Interface Material	Honeywell*	N/A	PCM45F	Paula Knoll 858-279-2956 Paula_knoll@honeywell.com
Heat Sink Attach Clip	CCI/ACK*	A69230-001	N/A	Harry Lin (USA) 714-739-5797 <a href="mailto:hlinack@aol.com">hlinack@aol.com</a>  Monica Chih (Taiwan) 866-2-29952666, x131 Monica_chih@ccic.com.tw
	Foxconn*		N/A	Bob Hall (USA) 503-693-3509, x235 bhall@foxconn.com
Solder-down Anchor	Foxconn	A13494-005	N/A	Julia Jiang (USA) 408-919-6178 juliaj@foxconn.com

**Note:** These vendors and devices are listed by Intel as a convenience to Intel's general customer base, but Intel does not make any representations or warranties whatsoever regarding quality, reliability, functionality, or compatibility of these devices. This list and/or these devices may be subject to change without notice.

## Appendix B Mechanical Drawings

---

This appendix contains the following mechanical drawings:

Drawing Name	Page Number
Package Drawing	21
Reference Thermal Solution Assembly	22
1U Copper Heat Sink	23
Heat Sink Gasket	24
Torsional Heat Sink Attach Clip	25

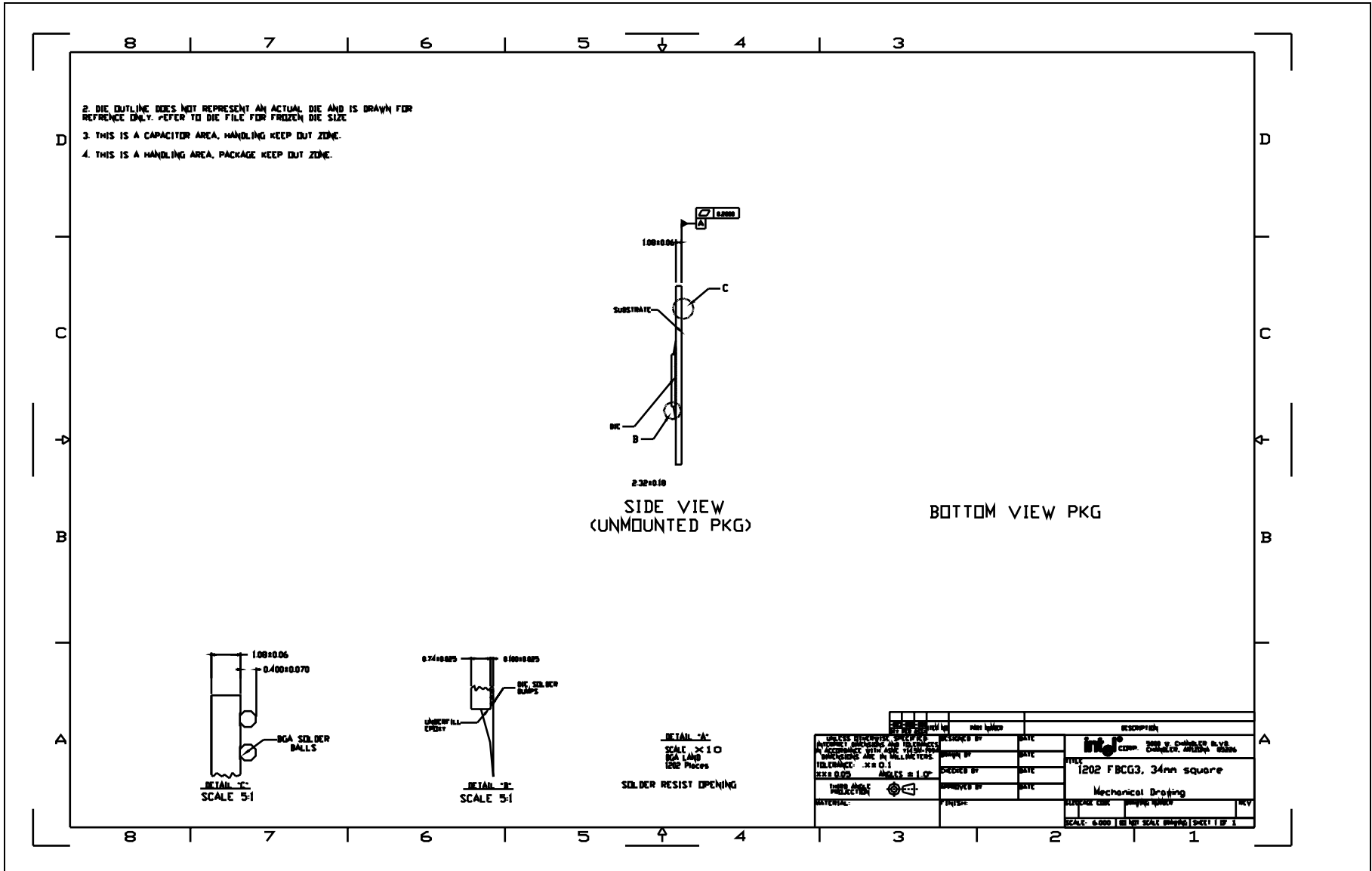

Figure 2 Reference Thermal Solution Assembly

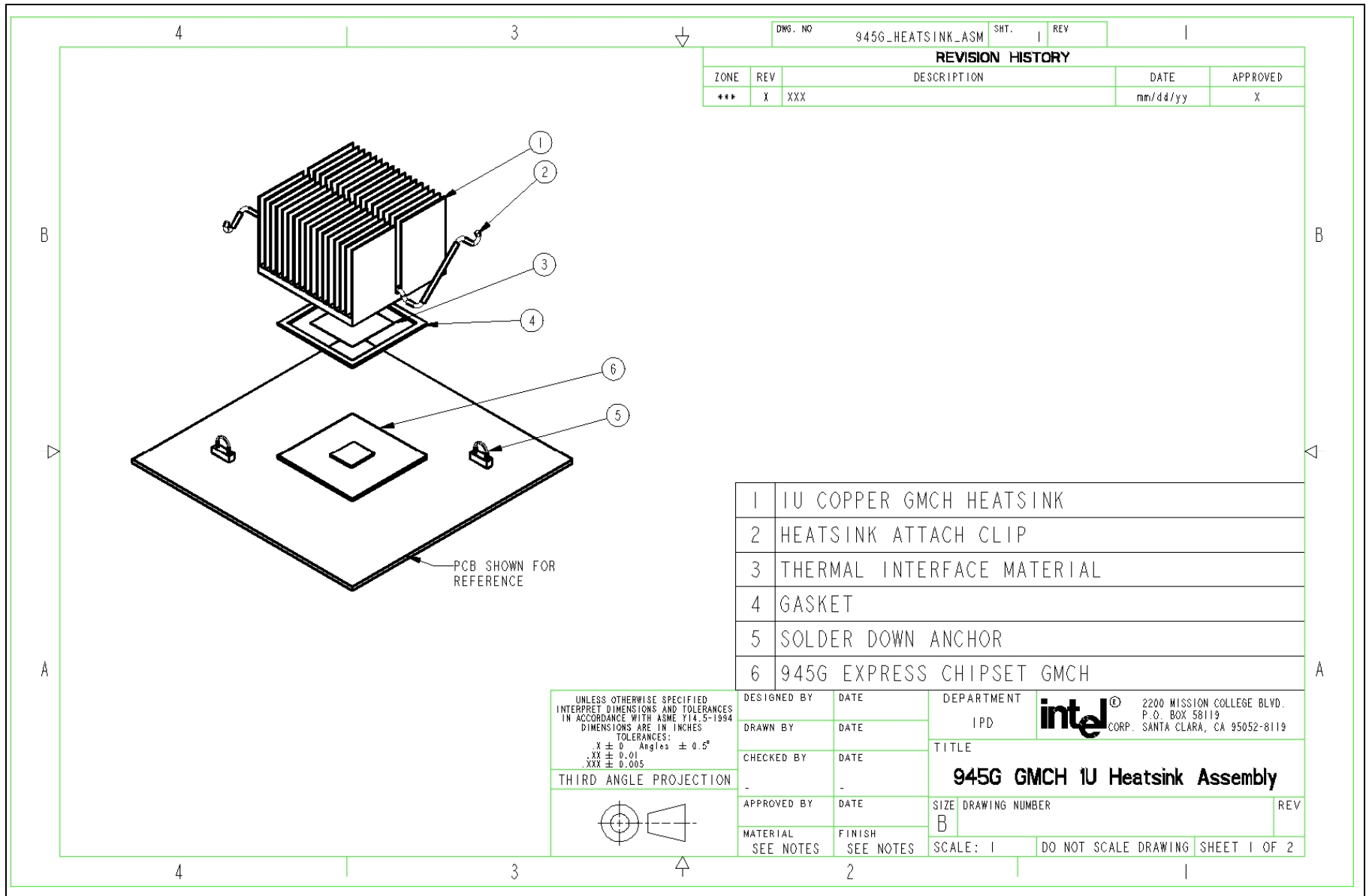

Figure 3 1U Copper Heat Sink

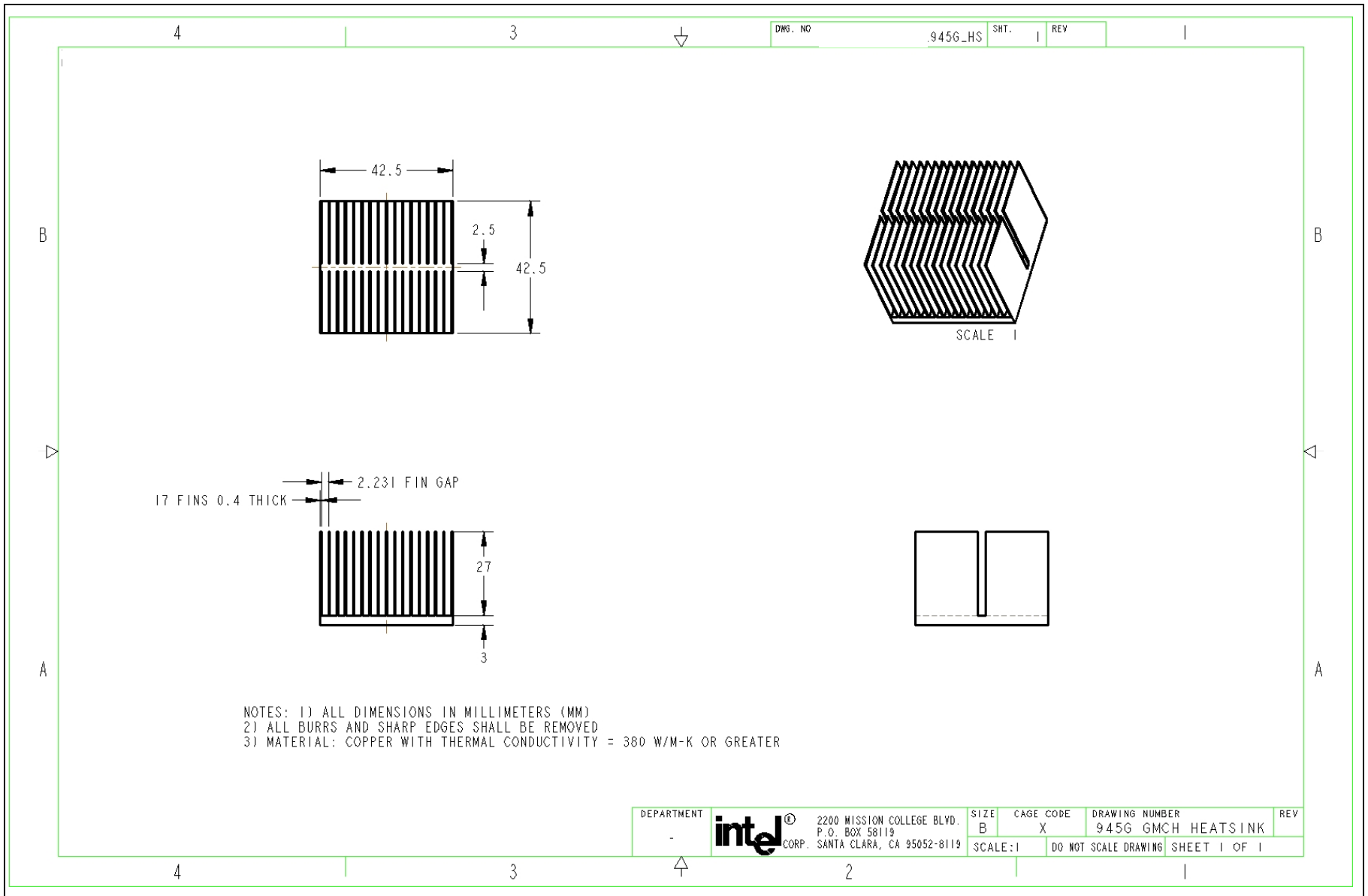

Figure 4 Heat Sink Gasket

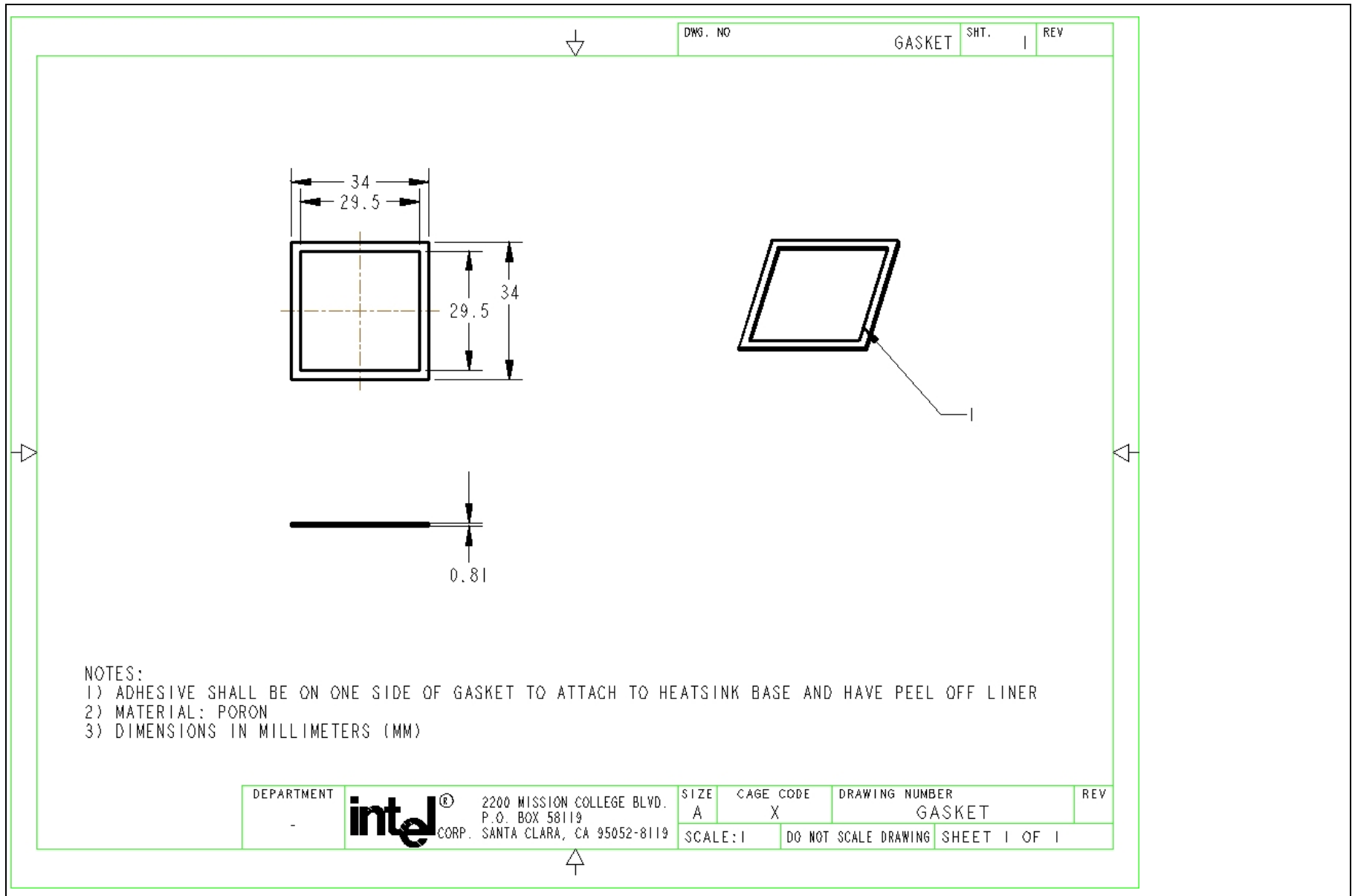

Figure 5 Torsional Heat Sink Attach Clip

